



Schindler 3000

Stylish, functional and flexible

We Elevate



Schindler



A flexible solution that unifies form and function. An all-round elevator applicable to multiple building types, with outstanding architectural flexibility for car, door and shaft dimensions. Swiss precision engineering and latest technologies assure a smooth and safe user experience.



Schindler 3000

Stylish, functional and flexible

Schindler 3000 offers a large variety of design and dimensional combinations, and can be tailored to multiple applications in any urban environment. Select from a full spectrum of styles, colors and options to find the best possible match for your building.

Schindler 3000 is part of Schindler's new, modular-platform product range for all residential and commercial buildings, from low-to mid-rise, and from basic to sophisticated requirements, worldwide.

Key figures

Capacity	320–1350 kg
Travel height	Up to 80 m
Stops	Max 25 stops
Speed	1,0 ; 1,6 m/s
Drive system	Machine-room-less, eco-friendly regenerative drive technology, frequency controlled
Group size	Up to 4 cars
Entrances	One- or two-sided
Interior	3 interior design lines, fresh wall colors and wide range of fixtures, and bare car option

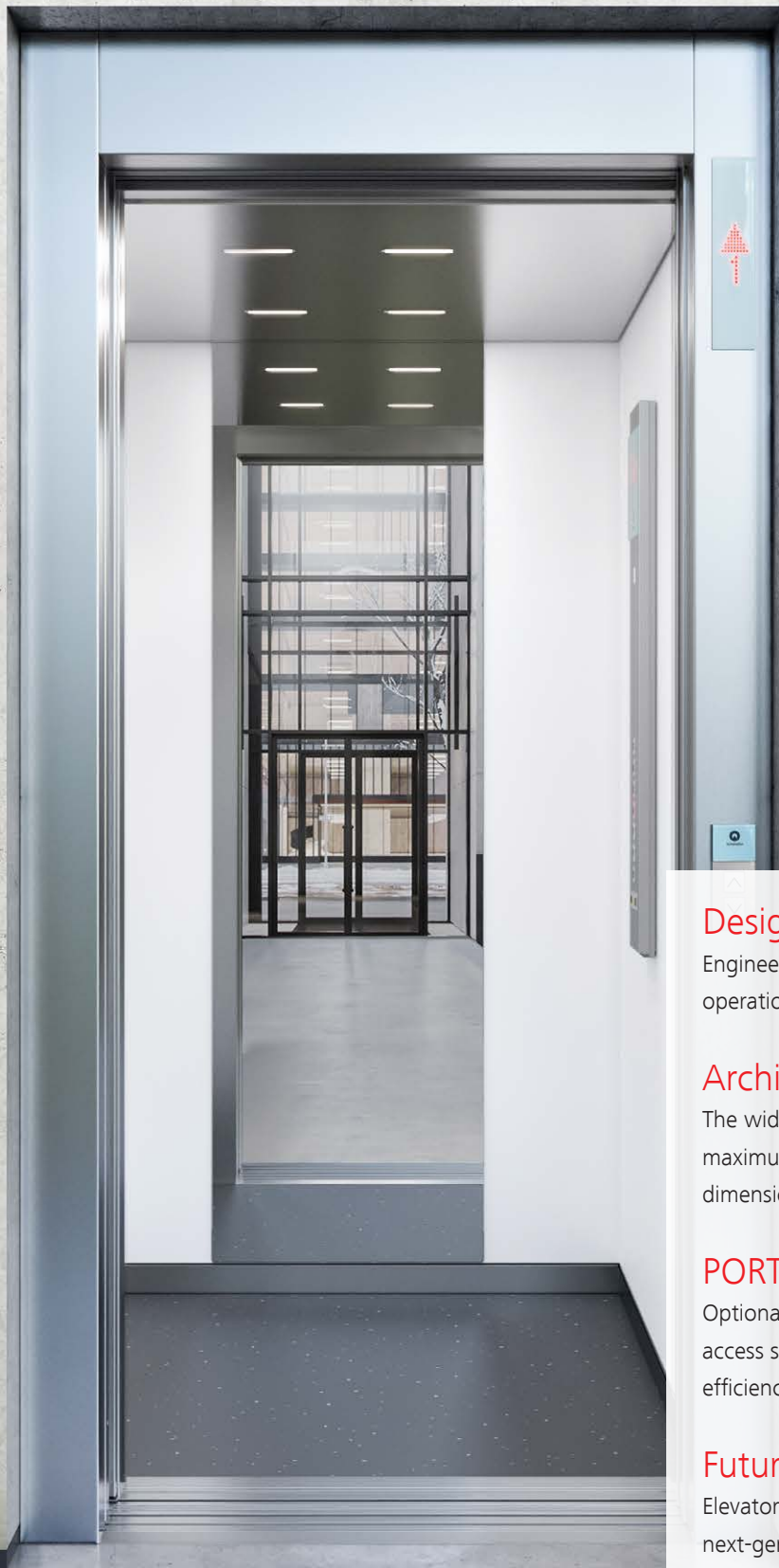

Designed for comfort

Engineered to Swiss standards for 24/7 operation and smooth ride comfort.

Architectural flexibility

The widest range of applications, plus maximum flexibility in car and shaft dimensions.

PORT Technology

Optional integrated building security access solution, plus increased elevator efficiency and comfort.

Future ready

Elevators designed to interface with next-generation technologies.

Multiple design options

Three full design lines to complement your building interior, or choose your own design.

Designed for comfort – built to last

Engineered to Swiss standards

Schindler 3000 is designed, engineered and rigorously tested to ensure smooth, quiet and economical operation throughout your elevator's long life cycle, for every application, and in any environment.



Latest technologies, greater comfort

Variable frequency drive systems deliver perfectly controlled power to traction machines and door drives, extending component lifetimes and increasing energy efficiency. Schindler Suspension Traction Media is light and long-lasting, enabling the use of smaller traction machines that reduce both energy consumption and noise and vibration levels in the car.

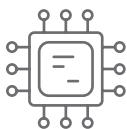

State-of-the-art digital controller

Schindler's scalable (universal) elevator controller offers more flexibility in number of openings, number of stops, and car group size. What's more, Schindler's innovative EPIC absolute positioning system improves both reliability and maintainability.



High-quality – at every level

Contact-free sensors assure millimeter-precise leveling with the floor for safe, seamless movement of passengers and goods in and out of the elevator.



Innovative drive technology

Schindler 3000 is equipped as standard with our innovative, regenerative drive technology. The system is designed to reduce travel energy by up to 30% compared to conventional technology.



Excellent ecological performance

Improving energy efficiency is essential to reduce the environmental impact of elevators and the buildings they serve. Regenerative drive, LED lighting and stand-by mode while parked, are standard eco-friendly features in all Schindler 3000 elevators, aiming to achieve the highest energy-efficiency rating class A according to ISO 25745-2*.

*The classification always refers to a specific customer configuration. Usage pattern, load capacity, customer specific options and site conditions influence the final rating.

Access control and transit intelligence

The revolutionary PORT Technology

All Schindler 3000 elevators are enabled for our revolutionary PORT Technology, with all the advantages of reduced travel time in elevators, higher passenger traffic capacity, and the potential for full building security and personalized access. PORT makes buildings more attractive, more efficient, and more valuable.



Architectural flexibility

Less space, more capacity

Schindler 3000 has outstanding architectural flexibility for car, door and shaft dimensions. Less space for components, more room for you to use profitably.

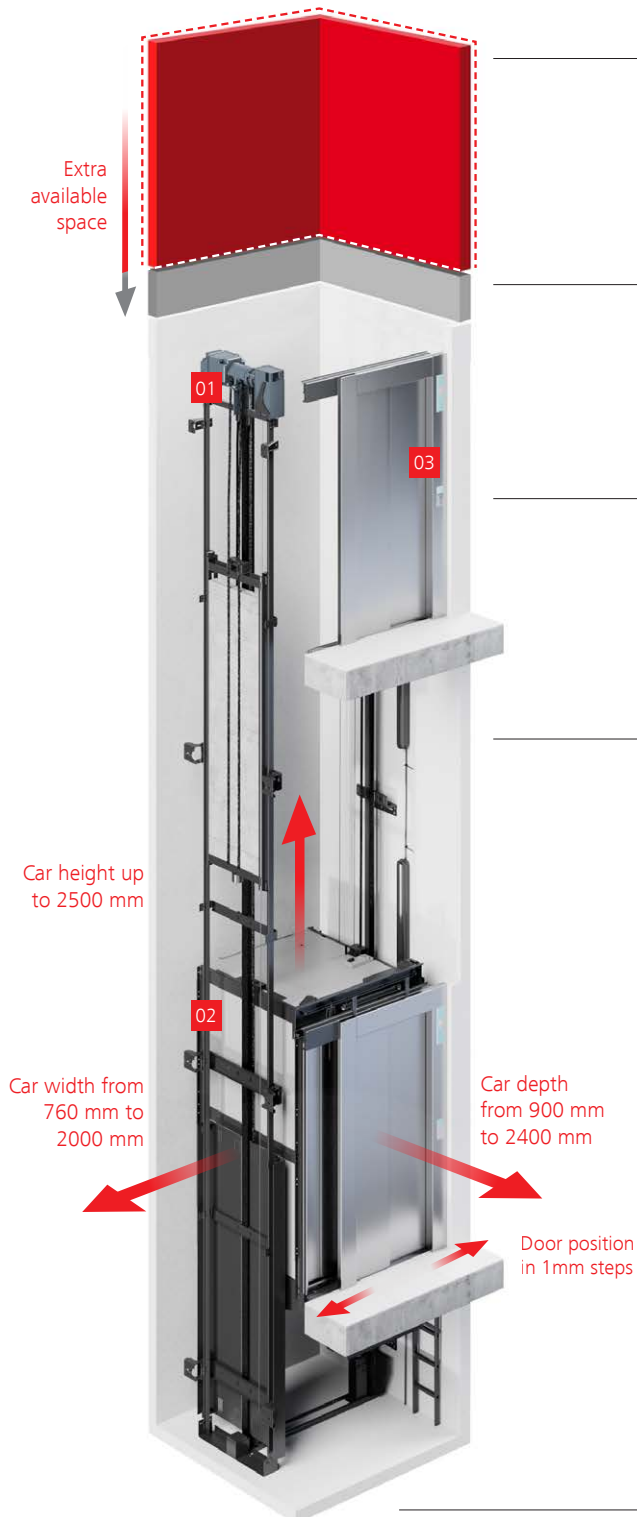

Machine-room-less design

All main drive, traction and control equipment sits in the shaft, leaving architects and designers free to use the extra space for more productive purposes. And thanks to the compact gearless machine, a larger car can be fitted into a standard shaft space, reducing headroom space and pit depth.

Reduced headroom

It offers even more room for you making the installation highly flexible.

Built-in inspection and test panel

The control is integrated as a compact element directly in the standard door frame.

Modular system, scalable car and door dimensions

We can adjust car dimensions for you in any direction in 10 mm increments. Schindler 3000 car width is available from 760 mm to 2000 mm, car depth from 900 mm to 2400 mm, and car height can right up to 2500 mm. Doors can be sized and positioned with millimeter accuracy. The door width is adjustable in 50 mm increments for heights from 2000 mm to 2400 mm, with a choice of telescopic (T2) or center-opening doors (C2, C4) and single or double (through-loading).

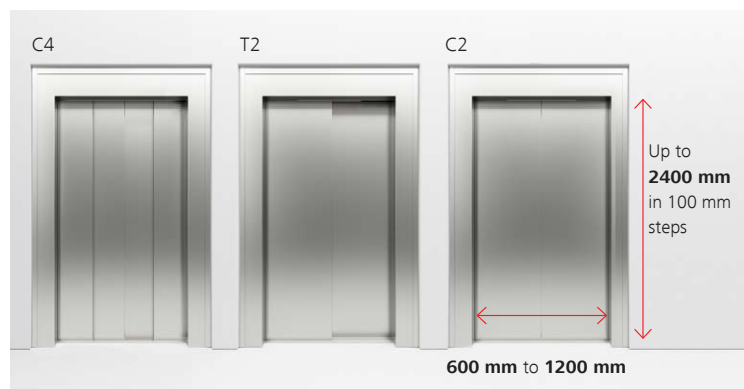

Reduced pit depth

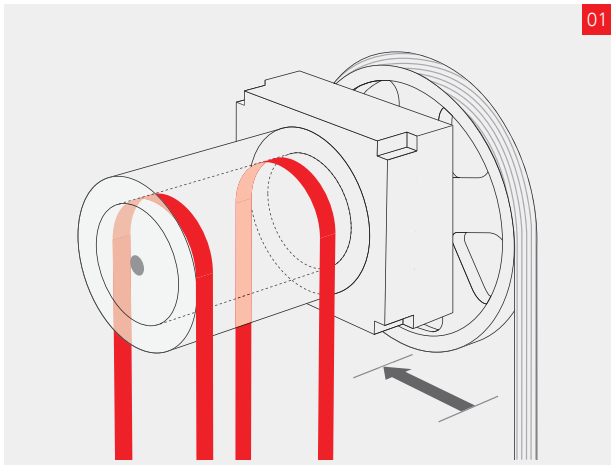

Smaller motor and traction sheave

Schindler's Suspension Traction Media (STM) system guarantees a quieter, smoother ride and does not require any oil or lubricant. STM also saves shaft space because of the smaller motor and traction sheave – 70% smaller than traditional systems. For passengers that means a better ride, while building owners will appreciate the increased reliability and efficiency.

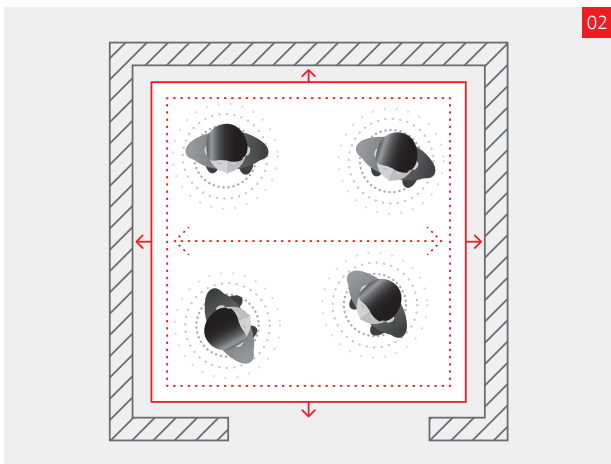

More usable building space

Less space for components, more usable building space and more room for passengers. Schindler 3000's innovative platform ensures that a standard-sized shaft can carry a wider car with bigger load capacity.



Built-in inspection and test panel

Schindler 3000's inspection and test panel is built directly into a standard door frame at the top landing.

This solution simplifies elevator installation, provides easy access, and saves space.

Navona
Functional and durable



Times Square
Modern and versatile

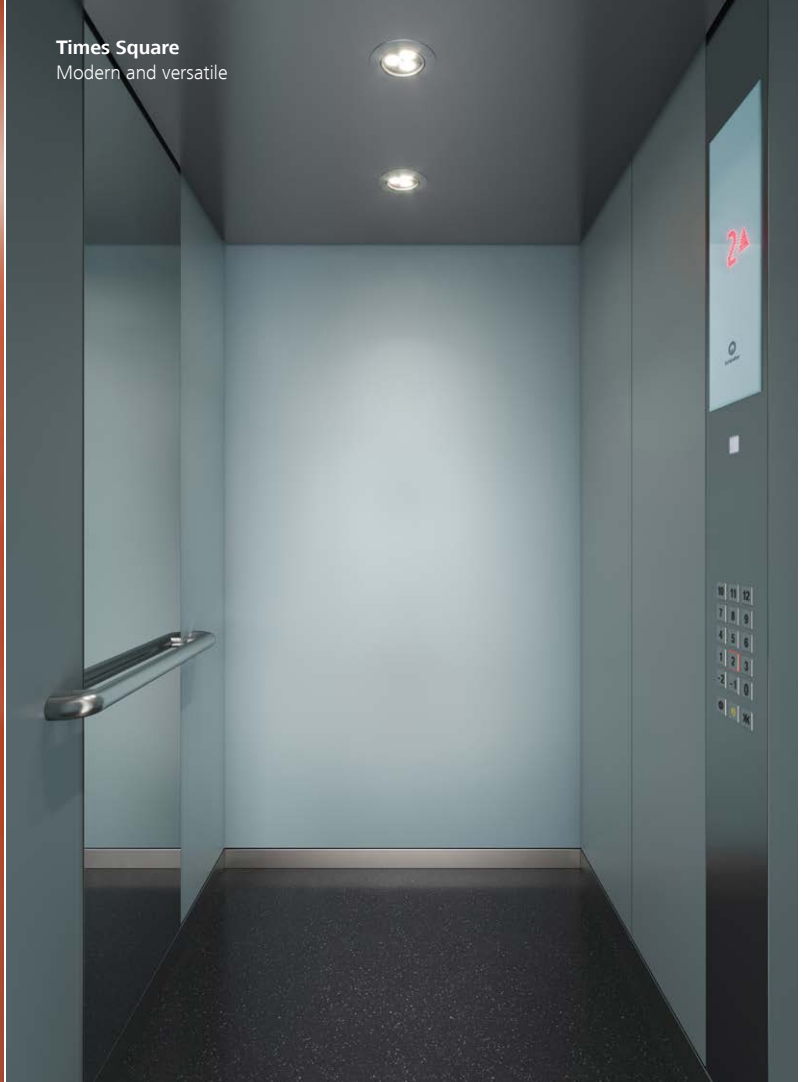

Multiple design options

Ready-made interior design lines

Navona

Functional and durable

Clarity and comfort in your car with this robust design line. Fresh colors, durable accessories, and the option of five different floors make Navona an excellent choice for residential applications. Stainless steel options are also available for rear and side walls.

Park Avenue

Sophisticated and elegant

A touch of class. Wooden and textured laminates or back-painted glass walls for a rich, contemporary mode. Or a luxury feel with stainless steel in seven different finishes or decorative glass. Matched lighting completes Park Avenue's elegance.

Times Square

Modern and versatile

A contemporary look. Choose from warm or cool colors or combine to enhance contrast for more depth. Times Square adds distinctive features to any public, commercial or residential building.

Note: Specifications, options and colors are subject to change. All cars and options illustrated in this brochure are representative only. The samples shown may vary from the original in color and material.



Freedom of design

Create the look and feel you like

Choose an elevator design that perfectly matches your building interior. Select from Schindler 3000's three décor lines and combine your choice with our range of operating panels, handrails, lighting, mirrors and other accessories.

And for full custom designs, the Schindler 3000 bare car option allows you to add up to 30% of the car's rated load capacity for the materials and finishings of your choice.



Design your elevator in minutes

Explore the wide range of combinations available with our easy-to-use online Plan & Design Tool:
digitalplan.schindler.com



Car operating panels and landing fixtures

Outfit your elevator with style

Linea 100

Linea 100 offers functional design in stainless steel. The integrated white glass display comes with large, easily readable red LED dot matrix floor indicator. Push buttons have clear red illumination when a call is recognized.

Linea 100 Touch

The convenience of our typical user interface converted to a touch version. The stylish design is in resistant glass with light indication to signal all functions, and dot matrix displays with large, easily readable red LEDs.

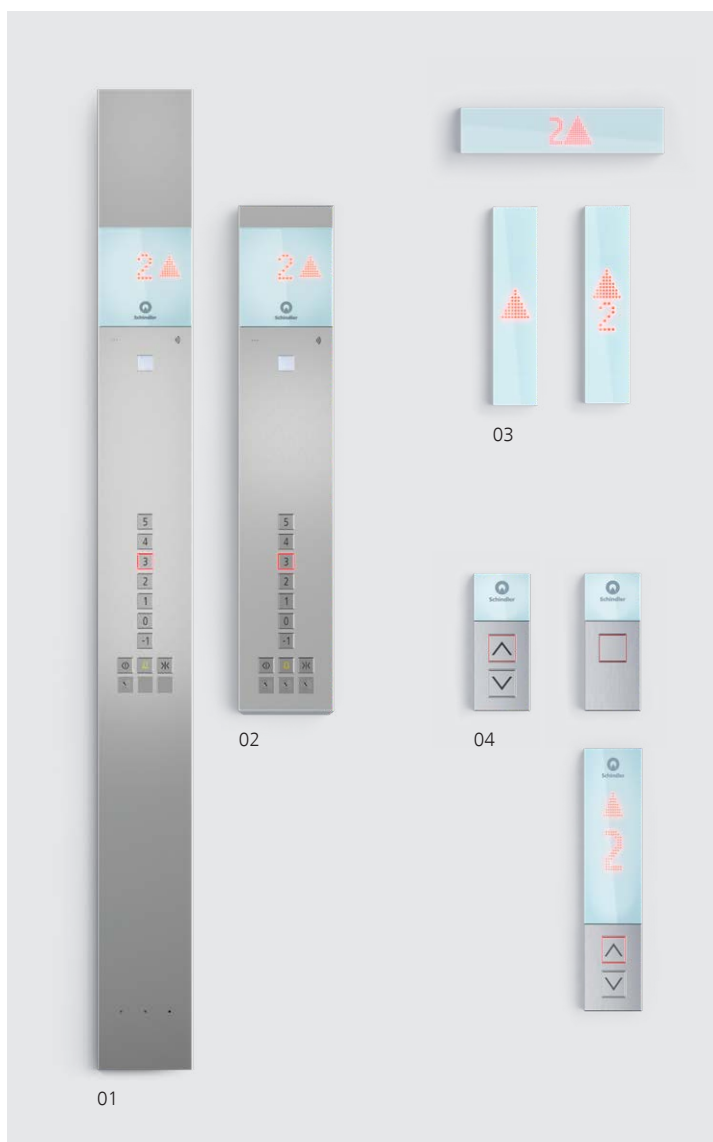

- 01 Full height car operating panel
- 02 Half height car operating panel
- 03 Car position & direction indicators
- 04 Landing operating panels

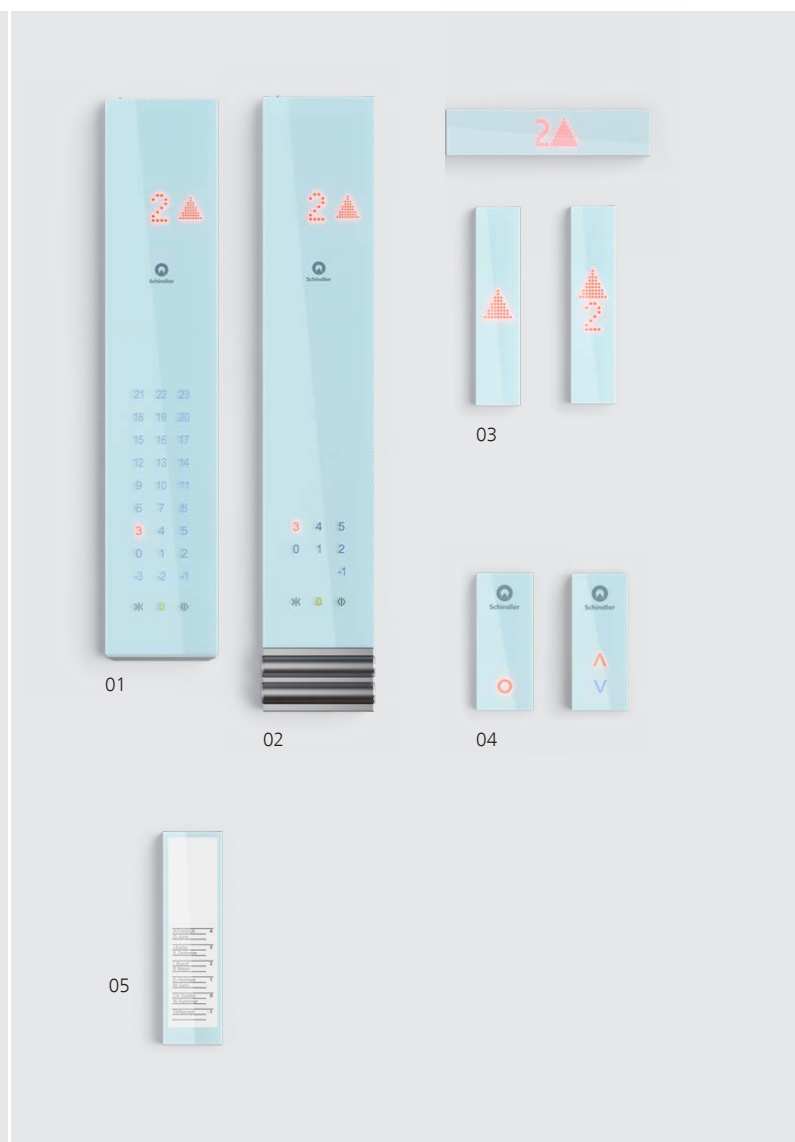

- 01 Car operating panel
- 02 Car operating panel with key switch
- 03 Car position & direction indicators
- 04 Landing operating panels
- 05 Name / information plate

Linea 300

An upmarket user interface to enhance your elevator's looks, with an intuitive, efficient design. The display is in black glass, with buttons positioned on elegant black stainless steel, or white glass display on typical stainless steel color finishing.

EN 81-70 fixtures

Our Fixtures are also available to be compliant with EN81-70:2018. All guidelines, like differences in contrast, arrangement of symbols and their size, are taken into account.



- 01 Full height car operating panel, flush
- 02 Car position & direction indicators
- 03 Landing operating panels



- 01 Half height car operating panel, EN 81-70:2018
- 02 Car position & direction indicators
- 03 Landing operating panel, EN 81-70:2018
- 04 XL-Landing operating panel, EN 81-70:2018
- 05 XL-Horizontal car operating panel, EN 81-70:2018

Planning Data

Standard

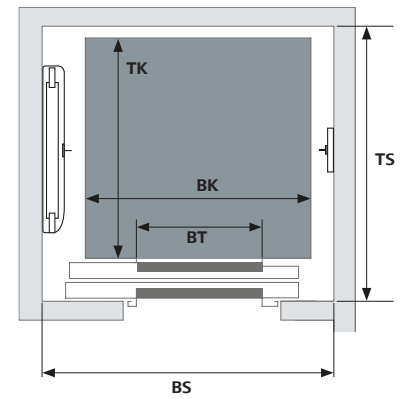

Machine room-less traction elevator with frequency-controlled drive; with 1 or 2 entrances

GQ / Pers. kg	VKN m/s	HQ m	Car			Doors			Shaft							
			BK ⁽¹⁾ mm	TK mm	HKC mm	Type	BT mm	HT mm	BS mm	TS ⁽¹⁾ mm	TS ⁽²⁾ mm	HSG ⁽¹⁾ mm	HSG ⁽²⁾ mm	HSK ⁽¹⁾ mm	HSK ⁽²⁾ mm	
320 / 4	1,0	45	900	1000	2100/2200	T2	750	2000	1400	1350	–	1450	800	3800/3900	3150	
400 / 5	1,0	45	1000	1100	2100/2200	T2	750	2000	1400	1450	1650	1100	820	3400/3500	2900/3000	
535 / 7	1,0	60	1050	1250	2100/2200/*	T2	800	2000/2100	1450	1600	1800	1100	820	3400/3500/*	2900/3000/*	
	1,0	60	1050	1300	2100/2200/*	T2	800	2000/2100	1450	1650	1850	1100	820	3400/3500/*	2900/3000/*	
	1,6	66	1050	1250	2100/2200/**	T2	800	2000/2100	1450	1600	1800	1250	–	3600/3700/**	–	
	1,6	66	1050	1300	2100/2200/**	T2	800	2000/2100	1450	1650	1850	1250	–	3600/3700/**	–	
625 / 8	1,0	60	1200	1250	2100/2200/*	T2	800/900	2000/2100 ^o	1600	1600	1800	1100	820	3400/3500/*	2900/3000/*	
	1,0	60	1200	1300	2100/2200/*	T2	800/900	2000/2100 ^o	1600	1650	1850	1100	820	3400/3500/*	2900/3000/*	
	1,6	75	1200	1250	2100/2200/**	T2	800/900	2000/2100 ^o	1600	1600	1800	1250	–	3600/3700/**	–	
	1,6	75	1200	1300	2100/2200/**	T2	800/900	2000/2100 ^o	1600	1650	1850	1250	–	3600/3700/**	–	
630 / 8 	1,0	60	1100	1400	2100/2200/*	T2	800/900	2000/2100 ^o	1600	1750	1950	1100	820	3400/3500/*	2900/3000/*	
	1,6	75	1100	1400	2100/2200/**	T2	800/900	2000/2100 ^o	1600	1750	1950	1250	–	3600/3700/**	–	
675 / 9 	1,0	60	1200	1400	2100/2200/*	T2	800/900	2000/2100 ^o	1600	1750	1950	1100	820	3400/3500/*	2900/3000/*	
	1,0	60	1200	1400	2100/2200/*	C2	900	2000/2100	2000	1700	1800	1100	820	3400/3500/*	2900/3000/*	
	1,6	75	1200	1400	2100/2200/**	T2	800/900	2000/2100 ^o	1600	1750	1950	1250	–	3600/3700/**	–	
	1,6	75	1200	1400	2100/2200/**	C2	900	2000/2100	2000	1700	1800	1250	–	3600/3700/**	–	
800 / 10 	1,0	60	1400	1400	2100/2200/**	C2	900	2000/2100	2000	1700	1800	1100	820	3800/3900/**	2900/3000/*	
	1,6	75	1400	1400	2100/2200/”	C2	900	2000/2100	2000	1700	1800	1250	–	4000/4100/”	–	
900 / 12 	1,0	60	1100	1850	2100/2200/**	T2	800/900	2000/2100 ^o	1600	2200	2400	1100	820	3800/3900/**	2900/3000/*	
	1,6	75	1400	1500	2100/2200/”	C2	900	2000/2100	2000	1800	1900	1250	–	4000/4100/”	–	
1000 / 13 	1,0	60	1100	2100	2100/2200/*	T2	900	2000/2100 ^o	1600	2450	2650	1100	820	3400/3500/*	2900/3000/*	
	1,6	75	1600	1400	2100/2200/**	C2	900	2000/2100	2000	1700	1800	1250	–	3600/3700/**	–	
1125 / 15 	1,0	60	1200	2100	2100/2200/*	T2	900	2000/2100 ^o	1650	2450	2650	1100	820	3400/3500/*	2900/3000/*	
	1,0	60	1200	2100	2100/2200/**	C2	900	2000/2100	2000	2400	2500	1100	820	3800/3900/**	2900/3000/*	
	1,6	75	1200	2100	2100/2200/**	T2	900	2000/2100 ^o	1650	2450	2650	1250	–	3600/3700/**	–	
	1,6	75	1200	2100	2100/2200/”	C2	900	2000/2100	2000	2400	2500	1250	–	4000/4100/”	–	

GQ Capacity
VKN Speed
HQ Max. travel height

* HKC=2300/2400 > HSK⁽¹⁾=3600/3700
HSK⁽²⁾=3100/3200
** HKC=2300/2400 > HSK⁽¹⁾=3800/3900
***HKC=2300/2400 > HSK⁽¹⁾=4000/4100
” HKC=2300/2400 > HSK⁽¹⁾=4200/4300
° HT=2300 > BT=900 > HKC=2300/2400

BK⁽¹⁾ Car width, for flush car operating panels: BK⁽¹⁾=BK - 50 mm

TK Car depth
HKC Clear car height, when using Schindler S3000 ceilings

T2 Telescopic door, 2-panels
C2 Center opening door, 2-panels

BT Door width
HT Door height

BS Shaft width
TS⁽¹⁾ Shaft depth 1 entrance
TS⁽²⁾ Shaft depth 2 entrances
HSG⁽¹⁾ Nominal pit depth
HSG⁽²⁾ min. Pit depth with Temporary Safety Device (optional)
HSK⁽¹⁾ min. Headroom height - depending on HKC (for safety gear on counterweight HSK min. + 70 mm)
HSK⁽²⁾ min. Headroom with Temporary Safety Device (optional)

All informations are in clear measure. The following applies to all planning variants:
Floor-to-floor distance (HE) is: min. 2400 mm for door height 2000 mm; min. 2500 mm for door height 2100 mm; min. 2700 mm for door height 2300 mm.
HE for two-stop installations is min. 2600 mm for door height 2000 mm and 2100 mm.
The shortest floor-to-floor distance for opposite entrances is 150 mm (min. HE for opposite entrances)
*EU type examination in accordance with Lifts Directive (Directive 2014/33/EU), based on EN 81-20.
We reserve the right to change the planning data due to technical developments. For different car dimensions, please contact us.

Car and doors dimensions compliant to EN 81-70:2018

Car and doors dimensions compliant to EN 81-70:2018; one wheelchair user of class C and some other passengers; allows transport of stretchers

Planning Data

Standard

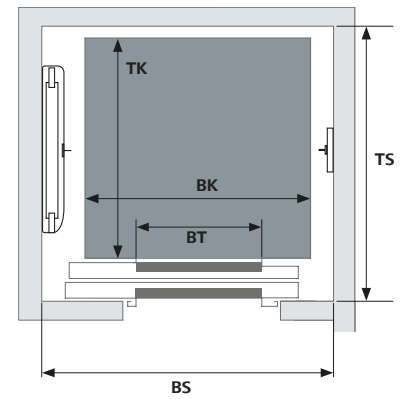

Machine room-less traction elevator with frequency-controlled drive; with 1 or 2 entrances

GQ / Pers. kg	VKN m/s	HQ m	Car			Doors			Shaft				
			BK mm	TK mm	HKC mm	Type	BT mm	HT mm	BS mm	TS ⁽¹⁾ mm	TS ⁽²⁾ mm	HSG mm	HSK mm
1.150 / 15 	1,0	60	1200	2100	2200	T2	1000	2100	1830	2500	2680	1100	3600
	1,0	60	1200	2100	2200	T2	1100	2100	1980	2500	–	1100	3600
	1,6	80	1200	2100	2200	T2	1000	2100	1830	2500	2680	1250	3800
	1,6	80	1200	2100	2200	T2	1100	2100	1980	2500	–	1250	3800
1.200 / 16 	1,0	60	1200	2100	2200	T2	1100	2100	1980	2500	2680	1100	3600
	1,0	60	1200	2300	2200	C2	1100	2100	2380	2600	2750	1100	3600
	1,6	80	1200	2100	2200	T2	1100	2100	1980	2500	2680	1250	3800
	1,6	80	1200	2300	2200	C2	1100	2100	2380	2600	2750	1250	3800
1.275 / 17 	1,0	60	1200	2300	2200	T2	1100	2100	1980	2700	–	1100	3600
	1,6	80	1200	2300	2200	T2	1100	2100	1980	2700	–	1250	3800
1.350 / 18 	1,0	60	1200	2300	2200	T2	1100	2100	1980	2700	2880	1100	3600
	1,6	80	1200	2300	2200	T2	1100	2100	1980	2700	2880	1250	3800
1.350 / 18 	1,0	60	1200	2400	2200	T2	1100	2100	1980	2800	2980	1100	3600
	1,6	80	1200	2400	2200	T2	1100	2100	1980	2800	2980	1250	3800
1.350 / 18 	1,0	60	1350/1400	2100	2200	T2	1100	2100	1980	2500	2680	1100	3600
	1,6	80	1350/1400	2100	2200	T2	1100	2100	1980	2500	2680	1250	3800
1.350 / 18 	1,0	60	1400	2100	2200	C2	1100	2100	2450	2400	2550	1100	3600
	1,6	80	1400	2100	2200	C2	1100	2100	2450	2400	2550	1250	3800
1.350 / 18 	1,0	60	2000	1500	2200	C2	1100	2100	2530	1800	1950	1100	3600
	1,6	80	2000	1500	2200	C2	1100	2100	2530	1800	1950	1250	3800

GQ Capacity
VKN Speed
HQ Max. travel height

BK Car width
TK Car depth
HKC Clear car height, when using Schindler S3000 ceilings

T2 Telescopic door, 2-panels
C2 Center opening door, 2-panels
BT Door width
HT Door height

BS Shaft width
TS⁽¹⁾ Shaft depth 1 entrance
TS⁽²⁾ Shaft depth 2 entrances
HSG Nominal pit depth
HSK min. Headroom height

Car and doors dimensions compliant to EN 81-70:2018

Car and doors dimensions compliant to EN 81-70:2018; allows transport of stretchers

All informations are in clear measure. The following applies to all planning variants:

Floor-to-floor distance (HE) is (HT + 400 mm), (HT + 450 mm) or (HT + 480 mm) - depending on the door type.

Car height (HK) is (HKC + 100 mm). Clear car height (HKC) can be up to 2400 mm > min. Headroom height HSK is higher accordingly.

There are larger HSG / HSK dimensions for the safety gear on the counterweight (when space below the counterweight is available for people).

Different planning values apply for elevators with earthquake requirements. Please note our information on tolerances on our layout drawings.

EU type examination in accordance with Lifts Directive (Directive 2014/33/EU), based on EN 81-20.

We reserve the right to change the planning data due to technical developments. For different car dimensions, please contact us.

Planning Data

Flexible car options

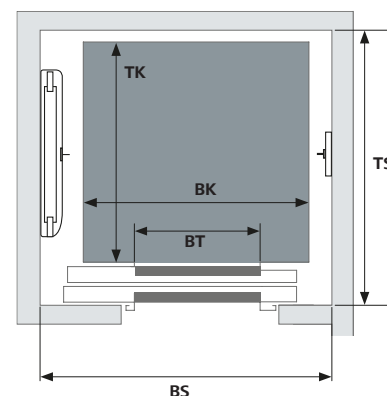

Machine room-less traction elevator with frequency-controlled drive; with 1 or 2 entrances

GQ / Pers. kg	VKN m/s	HQ m	Car			Doors			Shaft				
			BK ⁽¹⁾ mm	TK mm	HKC mm	Type	BT mm	HT mm	BS mm	TS ⁽¹⁾ mm	TS ⁽²⁾ mm	HSG mm	HSK mm
675 / 9 	1,0	< 45	1200	1400	2100	C4	1100	2100	1800	1700	1860	820	2900
	1,0	< 45	1200	1400	2100 - 2400	T2	900	2000 - 2300	1600	1700	1860	820	2900 - 3200
	1,0	< 45	1200	1400	2100 - 2400	C2	900	2000 - 2300	2000	1650	1730	820	2900 - 3200
	1,6	75 ^(*)	1200	1400	2100	C4	1100	2100	1800	1700	1860	1250	3600
	1,6	75 ^(*)	1200	1400	2100 - 2400	T2	900	2000 - 2300	1600	1700	1860	1250	3600 - 3900
	1,6	75	1200	1400	2100 - 2400	C2	900	2000 - 2300	2000	1650	1730	1250	4000 - 4300
1.125 / 15 	1,0	< 45	1200	2100	2100	C4	1100	2100	1800	2400	2560	820	2900
	1,0	< 45	1200	2100	2100 - 2400	T2	900	2000 - 2300	1650	2400	2560	820	2900 - 3200
	1,0	< 45	1200	2100	2100 - 2400	C2	900	2000 - 2300	2000	2350	2430	820	2900 - 3200
	1,6	75	1200	2100	2100	C4	1100	2100	1800	2400	2560	1250	4000
	1,6	75	1200	2100	2100 - 2400	T2	900	2000 - 2300	1650	2400	2560	1250	3600 - 3900
	1,6	75	1200	2100	2100 - 2400	C2	900	2000 - 2300	2000	2350	2430	1250	4000 - 4300
1.275 / 17 	1,0	60	1350	2100	2100 - 2400	C2	1100	2000 - 2300	2400	2400	2550	1100	3500 - 3800
	1,0	60	1350	2100	2100 - 2400	C2	1200	2000 - 2400	2600	2450	2600	1100	3500 - 3800
	1,6	80	1350	2100	2100 - 2400	C2	1100	2000 - 2300	2400	2400	2550	1250	3700 - 4000
	1,6	80	1350	2100	2100 - 2400	C2	1200	2000 - 2400	2600	2450	2600	1250	3700 - 4000
1.350 / 18 	1,0	60	1350	2100	2100 - 2400	T2	1100	2000 - 2300	1980	2500	2680	1100	3500 - 3800
	1,0	60	1350	2100	2100 - 2400	T2	1200	2000 - 2400	2100	2500	2740	1100	3500 - 3800
	1,6	80	1350	2100	2100 - 2400	T2	1100	2000 - 2300	1980	2500	2680	1250	3700 - 4000
	1,6	80	1350	2100	2100 - 2400	T2	1200	2000 - 2400	2100	2500	2740	1250	3700 - 4000

<p>GQ Capacity</p> <p>VKN Speed</p> <p>HQ Max. travel height</p> <p>(*) HQ > 66 m → HSK + 80 mm</p>	<p>BK⁽¹⁾ Car width, for flush car operating panels: BK⁽¹⁾=BK - 50 mm</p> <p>TK Car depth</p> <p>HKC Clear car height, when using Schindler S3000 ceilings</p>	<p>T2 Telescopic door, 2-panels</p> <p>C2 Center opening door, 2-panels</p> <p>C4 Center telescopic opening door, 4-panels</p> <p>BT Door width</p> <p>HT Door height; height in 100 mm steps</p>	<p>BS Shaft width</p> <p>TS⁽¹⁾ Shaft depth 1 entrance</p> <p>TS⁽²⁾ Shaft depth 2 entrances</p> <p>HSG Pit depth</p> <p>HSK min. Headroom height - depending on HKC</p>
--	--	--	---

Car and doors dimensions compliant to EN 81-70:2018

Car and doors dimensions compliant to EN 81-70:2018; allows transport of stretchers

There are larger HSG / HSK dimensions for the safety gear on the counterweight (when space below the counterweight is available for people). We reserve the right to change the planning data due to technical developments. For different car dimensions, please contact us.

Planning Data

Low headroom

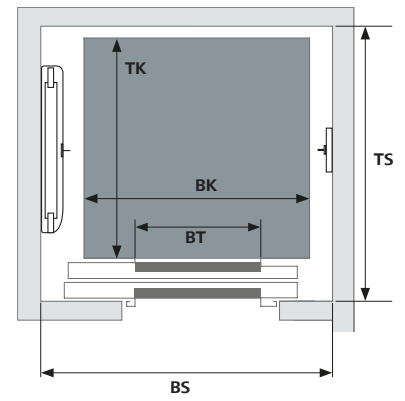

Machine room-less traction elevator with frequency-controlled drive; with 1 or 2 entrances

GQ / Pers. kg	VKN m/s	HQ m	Car			Doors			Shaft					
			BK mm	TK mm	HKC mm	Type	BT mm	HT mm	BS mm	TS ⁽¹⁾ mm	TS ⁽²⁾ mm	HSG mm	HSK ⁽¹⁾ mm	HSK ⁽²⁾ mm
450 / 6	1.0	< 45	1000	1250	2100	T2	800	2100	1550	1600	1800	960	2520	2420
480 / 6	1.0	< 45	1000	1300	2100	T2	800	2100	1550	1650	1850	960	2520	2420
630 / 8 	1.0	< 45	1100	1400	2100	T2	800/900	2100	1650	1750	1950	960	2520	2420
1.000 / 13 	1.0	< 45	1100	2100	2100	T2	900	2100	1650	2450	2650	960	2520	2420

BK Car width

HSG Pit depth

HSG min = 820 mm with HSK ≥ 2660 mm

HSG min = 960 mm with 2520 mm ≤ HSK ≤ 2660 mm

HSG min = 1060 mm with HSK=2420 mm

HSK⁽¹⁾ min. Headroom height

HSK⁽²⁾ HSK = 2420 mm with HKC = 2000 mm, HT = 2000 mm and HSG = 1060 mm

BS Shaft width

Car and doors dimensions compliant to EN

Car and doors dimensions compliant to EN 81-70:2018; allows transport of stretchers

Shaft dimensions

1 entrance

2 entrances, at 180°

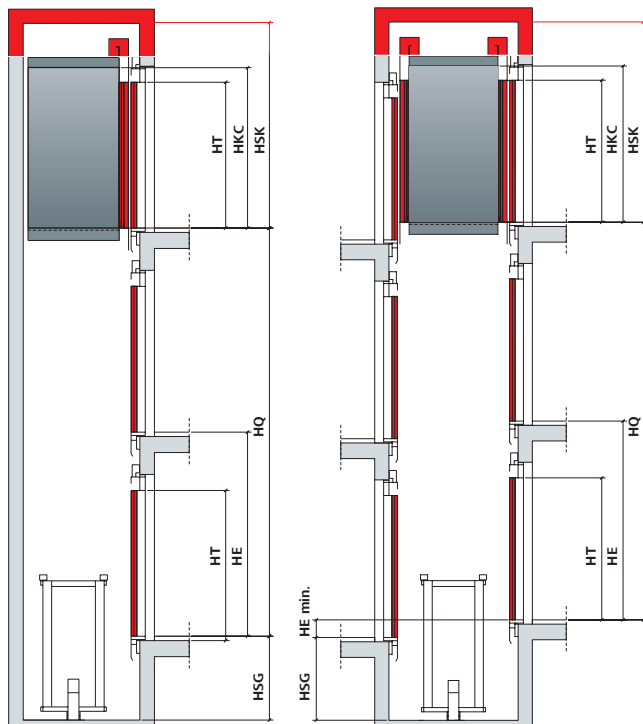

Doors

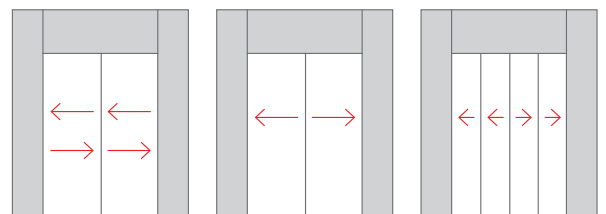

T2

C2

C4

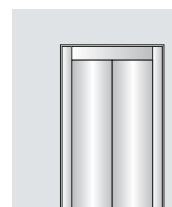

Basic / box frame landing doors

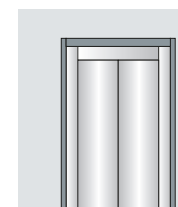

Adjustment frame landing doors with adjustment profile

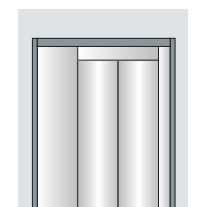

Landing doors with front and adjustment profile



Schindler Plan & Design Tool

Design your elevator layout in minutes

Our easy-to-use online Plan & Design tool makes it simple to design the look of your elevator. The Schindler Plan & Design tool helps you in choosing interior which best fits to your building. With just few clicks, we provide you with different variants and you can easily download pictures in great quality.



digitalplan.schindler.com

This publication is for general informational purposes only and we reserve the right at any time to alter the services, product design and specifications. No statement contained in this publication shall be construed as a warranty or condition, expressed or implied, as to any service or product, its specifications, its fitness for any particular purpose, merchantability, quality or shall be interpreted as a term or condition of any service or purchase agreement for the products or services contained in this publication. Minor differences between printed and actual colors may exist.

We Elevate



Schindler